

# SPECIFICATIONS FOR APPROVAL



Customer 聯發科技



Customer Part No. \_\_\_\_\_ HELE. Part No: X3S026000B71HZ-HPR  
Application For: MT-6253 Products: CRYSTAL  
Accepted Model: \_\_\_\_\_ Type & Freq.: HSX321S / 26.000MHZ  
Sample Order No: EOS-950289-1 Date: 2009/10/23

Approved By :

加高電子股份有限公司  
加高電子股份有限公司

**HARMONY ELECTRONICS CORP.**

**HARMONY ELECTRONICS (THAILAND) CO., LTD.**

**HARMONY ELECTRONICS (SHENZHEN) CORP., LTD.**

**TAIPEI OFFICE:**

公司:(114)  
台北市內湖區堤頂大道 2 段 409 號 2 樓  
2F., NO.409, SEC.2, TIDING BLVD.,  
NEIHU DISTRICT, TAIPEI CITY 114,  
TAIWAN (R.O.C.)  
TEL:886-2-26588883  
FAX:886-2-26588683

**TAIWAN FACTORY:**

工廠:(831)  
高雄縣大寮鄉大發工業區華東路 39 號  
NO. 39, HWA DONG RD., TA FA IND.  
DIST., TA LIAO KAOHSIUNG HSIEN 831,  
TAIWAN, R.O.C.  
TEL: (07)787-1555-6  
FAX: (07)787-1557

**THAILAND FACTORY:**

66MOO 5, KAONGU-BEOKPRAI RD.,  
T.BEOKPRAI, A. BANPONG,  
RAJCHABUREE PROVINCE 70110,  
THAILAND  
TEL: (032)221994-6, 200740-1  
FAX: (032)200742

**SHENZHEN FACTORY:**

深圳市福永鎮塘尾村塘橋路聚源工業區  
QIAO TANG RD., TANGWEI VILLAGE  
FU YONG TOWN SHENZHEN CITY  
CHINA  
TEL: 0755-7309272 / 7309262  
FAX: 0755-7309755

Title <b>HSX321S</b>				Country of origin <b>TAIWAN FACTORY</b>		
QUARTZ CRYSTAL SPECIFICATION				<b>THAILAND FACTORY</b>		
Date	Confirm	Check	Prepare	Spec. No.	Rev.	Page
<b>2009/10/23</b>	F. S. TSAI	C. L. WANG	U. F. CHEN	<b>X3S026000B71HZ-HPR</b>	1	1

**HARMONY ELECTRONICS CORP.**

# HSX321S SPECIFICATION

## INDEX

ITEM	PAGE
1. QUARTZ CRYSTAL UNIT SPECIFICATION . . . . .	3
2. MARKING & DIMENSIONS . . . . .	4
3. INSIDE STRUCTURE . . . . .	5
4. EMBOSS CARRIER TAPE&REEL . . . . .	
a. DIMENSIONS OF CARRIER TAPE . . . . .	6
b. DIMENSIONS OF REEL . . . . .	6-7
c. STORAGE CONDITION . . . . .	7
d. STANDARD PACKING QUANTITY . . . . .	7
e. MATERIAL OF TAPE . . . . .	7
f. LABEL CONTENTS . . . . .	7
g. TAPING DIMENSION . . . . .	8
h. JOINT OF TAPE . . . . .	8
i. RELEASE STRENGHT OF COVER TAPE . . . . .	8
5. MECHANICAL PERFORMANOE . . . . .	9
6. ENVIRONMENTAL PERFORMANOE . . . . .	9
7. SUPPLRMENT . . . . .	10-11
8. FLOW CHARD . . . . .	12
9. Environmental Workload Chemical Substance Components List .	13
10. TEST DATA . . . . .	

Title HSX321S QUARTZ CRYSTAL SPECIFICATION				Country of origin <b>TAIWAN FACTORY</b> <b>THAILAND FACTORY</b>		
Date	Confirm	Check	Prepare	Spec. No.	Rev.	Page
<b>2009/10/23</b>	F. S. TSAI	C. L. WANG	U. F. CHEN	<b>X3S026000B71HZ-HPR</b>	1	2

# 1. QUARTZ CRYSTAL UNIT SPECIFICATION

- |                                |   |
|--------------------------------|---|
| 1. Frequency:                  | 26.000000MHz  |
| 2. Holder type :               | <b>HSX321S</b>  |
| 3. Frequency tolerance:        | +/- 10 ppm at 25deg.C +/-3deg.C   |
| 4. Equivalent resistance:      | 30 ohms Max. / SERIES   |
| 5. Storage temperature range:  | -40 deg.C To +85 deg.C  |
| 6. Operable temperature range: | -20 deg.C To +75 deg.C  |
| 7. Temperature drift:          | +/- 10 ppm          -20 deg.C To +75deg.C                                   |
| 8. Loading capacitance (CL) :  | 7.2pF +/- 0.2 pF  |
| 9. Drive level:                | 100 uW +/- 10 uW  |
| 10. Shunt Capacitance:         | 2.0 pF Max  |
| 11. Insulation resistance :    | More than 500M ohms at DC 100V  |
| 12. Mode of oscillation:       | Fundamental   |
| 13. Circuit:                   | Measured in S&A 250B ,HP/E5100A   |
| 14. Shocking :                 | Dropping from 50 cm height 3 times on firm wood                             |
| Variation :                    | Frequency less than +/-5 ppm<br>Resistance less than +/- 15 % or 2ohms max. |
| 15. Aging:                     | Less than +/- 1 ppm/Year  |
| 16. Holder                     | HSX321S Seam type   |
| 17. Dimensions and marking     | Refer to page.4   |
| 18. Emboss carrier tape & reel | Refer to page.6 and page.7  |
| 19. Note:                      | TS : 32ppm/pF +/- 10%   |

Title <b>HSX321S</b>				Country of origin <b>TAIWAN FACTORY</b>		
<b>QUARTZ CRYSTAL SPECIFICATION</b>				<b>THAILAND FACTORY</b>		
Date	Confirm	Check	Prepare	Spec. No.	Rev.	Page
<b>2009/10/23</b>	F. S. TSAI	C. L. WANG	U. F. CHEN	<b>X3S026000B71HZ-HPR</b>	1	3

## 2. HSX321S MARKING & DIMENSIONS

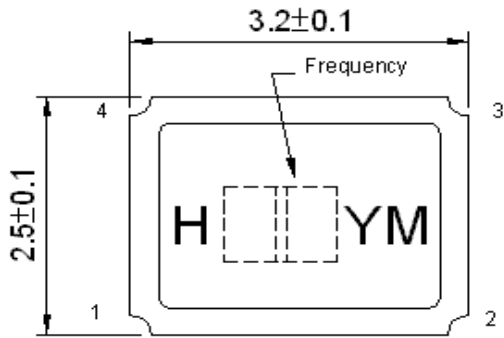

<TOP VIEW>

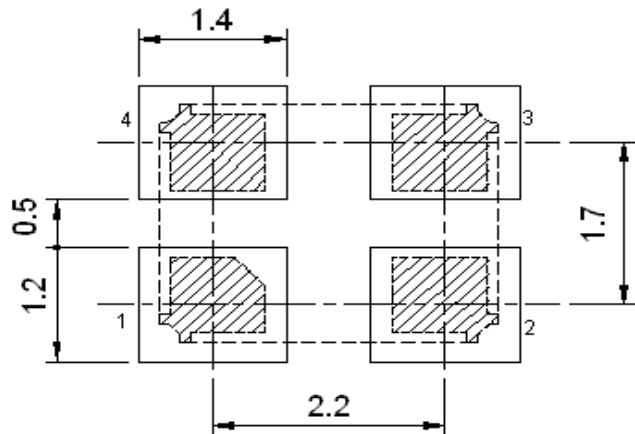
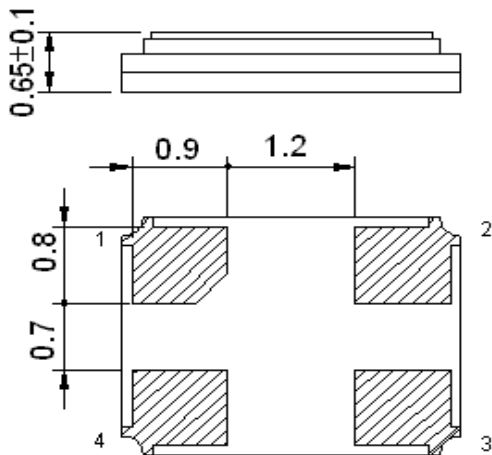
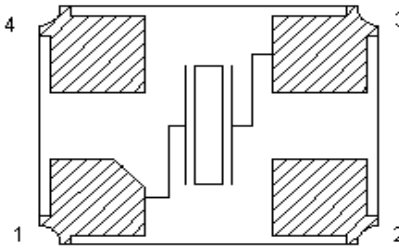

UNIT: mm

TOLERANCE:  $\pm 0.2$

\*Marking should be printed as following:

Logo, Nominal Frequency, Manufactured year & month

\*Nominal frequency = integer only

( ex. 14.31818 MHz  $\rightarrow$  14 )

\*Manufacturing Lot No.

(Y: year) ex. 2000 shall be marked as ' 0 ' (The last digit of the year)

(M: month) ex. June shall be marked as ' F ' (As shown on the Table-1).

Marking : Laser marking.

(Table-1)

Jan.	Feb.	Mar.	Apr.	May.	Jun.	Jul.	Aug.	Sep.	Oct.	Nov.	Dec.
A	B	C	D	E	F	G	H	J	K	L	M

Title HSX321S

QUARTZ CRYSTAL SPECIFICATION

Country of origin

**TAIWAN FACTORY**

**THAILAND FACTORY**

Date

Confirm

Check

Prepare

Spec. No.

Rev.

Page

2009/10/23

F. S. TSAI

C. L. WANG

U. F. CHEN

**X3S026000B71HZ-HPR**

1

4

**HARMONY ELECTRONICS CORP.**

### 3. INSIDE STRUCTURE

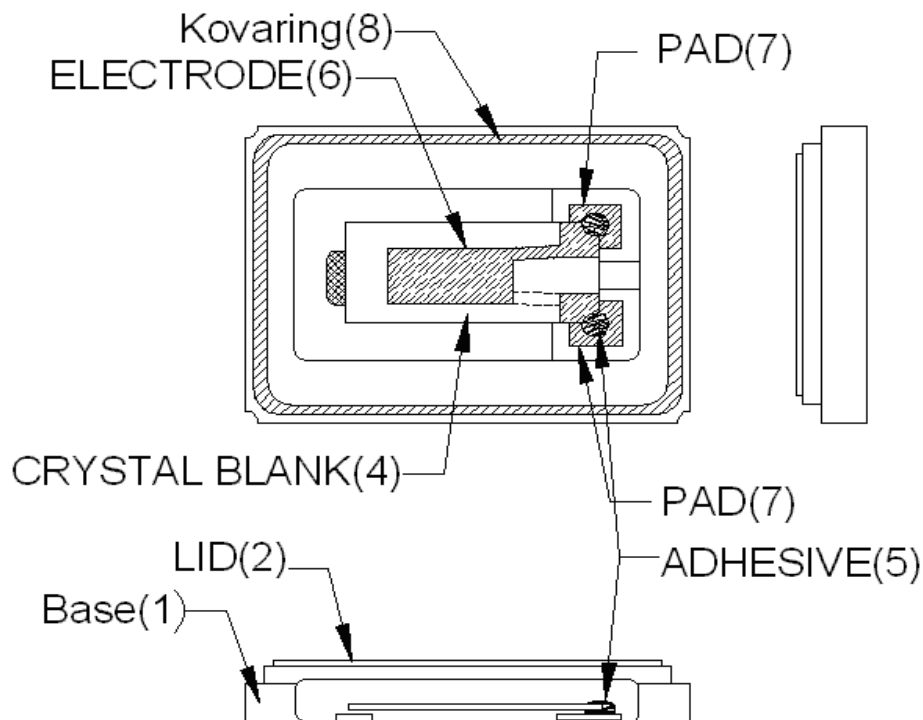

※Reference drawing

(1) Base: Alumina Ceramic ( $Al_2O_3$ ) Metallized Pad: W Ni Plating Au Plating Supplier: Kyocera NTK
(2) Lid : Fe- Ni -Co
(3) Crystal Enclosure Seal: Seal Seam
(4) Crystal Blank Rectangular At-Cut Quartz Crystal Blank
(5) Adhesive Silver Conductive Silicon Resin Adhesive bonding: upper & lower bonding/lower bonding only
(6) Electrode
(7) PAD Alumina Ceramic (W. Ni. Au)
(8) Kovaring : Fe-Ni-Co Alloy

The use prohibition chemistry substance of Table 1 of DHE-0204-1 (QA-QM-08) is not included in this item.

Title HSX321S

QUARTZ CRYSTAL SPECIFICATION

Country of origin

**TAIWAN FACTORY**

**THAILAND FACTORY**

Date	Confirm	Check	Prepare	Spec. No.	Rev.	Page
2009/10/23	F. S. TSAI	C. L. WANG	U. F. CHEN	X3S026000B71HZ-HPR	1	5

HARMONY ELECTRONICS CORP.

#### 4. HSX321S EMBOSS CARRIER TAPE & REEL

##### a.) Dimensions of Carrier Tape

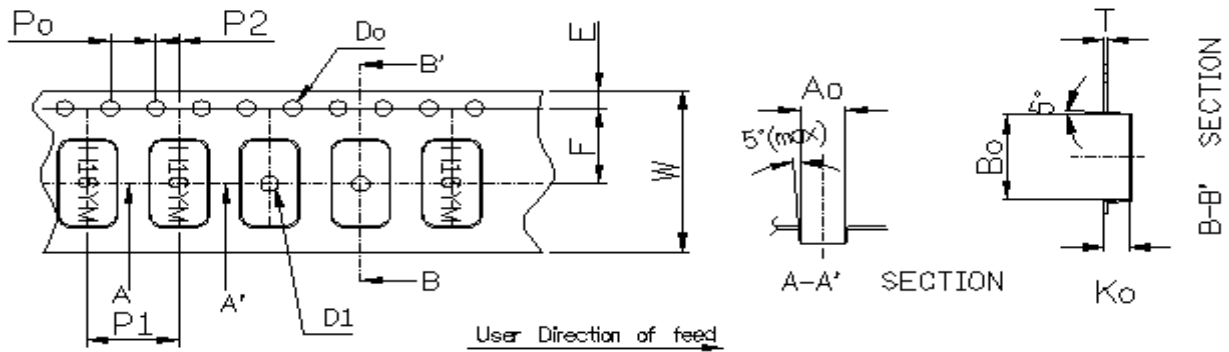

Symbol	Ao	Bo	Ko	Po	P1	P2
Spec	2.70±0.1	3.4±0.1	1.40±0.1	4.0±0.1	4.0±0.1	2.0±0.05
Symbol	E	F	Do	D1	W	T
Spec	1.75±0.1	3.5±0.05	∅1.55±0.05	∅1.0<min>	8.0±0.2	0.25±0.05

##### b.) Dimensions of Reel

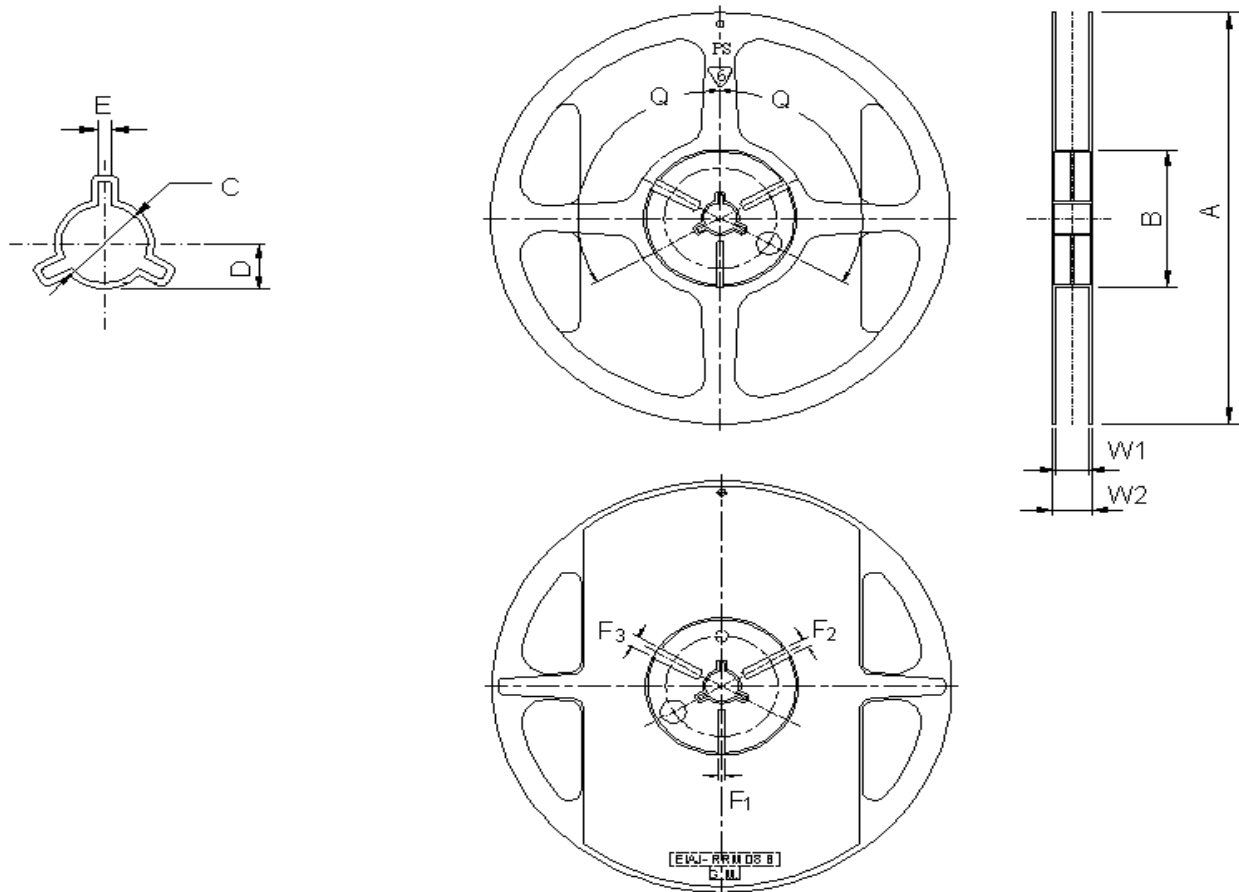

Title HSX321S QUARTZ CRYSTAL SPECIFICATION				Country of origin <b>TAIWAN FACTORY</b> <b>THAILAND FACTORY</b>		
Date	Confirm	Check	Prepare	Spec. No.	Rev.	Page
2009/10/23	F. S. TSAI	C. L. WANG	U. F. CHEN	<b>X3S026000B71HZ-HPR</b>	1	6

(Table-2)

(UNIT: mm)

ITEM		MARK	DIMENSIONS · ANGLE	
FLANCE	Diameter	A	$\phi$ 180+0/-3	
	Inner Width	W1	12.8+/-0.3	
	Outer Width	W2	15.5+/-1.0	
HUB	Out Line diameter	B	$\phi$ 60.5+/-0.5	
	Center Core slit	Width	F1	3.0+0.5/-0
			F2	4.0+0.5/-0
			F3	5.0+0.5/-0
		Position	q	120deg
	Spindle diameter		C	$\phi$ 13.2+/-0.5
Key Ditch	Width	E	3.0+/-0.2	

## c.) Storage condition

Temperature: +40deg.C Max.

Relative Humidity: 80% Max.

## d.) Standard packing quantity

3,000PCS / REEL

## e.) Material of the tape

Tape	Material
Carrier tape	PS Conductive
Top tape	Polyester

## f.) Label contents

- .The type of product
- .Our specification No.
- .Your Part No.
- .Lot No.
- .Nominal Frequency
- .Quantity
- .Our Company Name

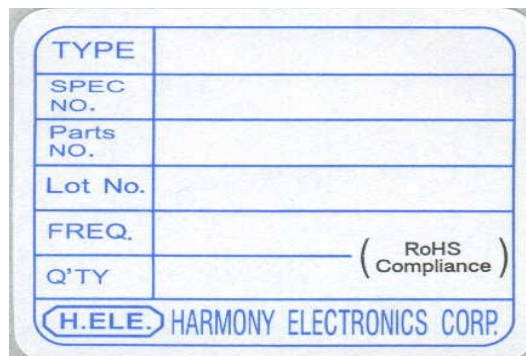

Sticks label for every reel.

Title HSX321S QUARTZ CRYSTAL SPECIFICATION				Country of origin <b>TAIWAN FACTORY</b> <b>THAILAND FACTORY</b>		
Date	Confirm	Check	Prepare	Spec. No.	Rev.	Page
<b>2009/10/23</b>	F. S. TSAI	C. L. WANG	U. F. CHEN	<b>X3S026000B71HZ-HPR</b>	1	7

HARMONY ELECTRONICS CORP.

g.) Taping dimension

Leader	Cover-tape	The length of cover-tape in the leader is more than 400 mm including empty embossed area.
	Carrier-tape	After all products were packaged, must remain more than twenty pieces or 400 mm empty area, which should be sealed by cover-tape.
Terminal	Cover-tape	The tip of cover-tape shall be fixed temporary by paper tape and roll around the core of reel one round.
	Carrier-tape	The empty embossed area which are sealed by top cover-tape must remain more the 40 mm.

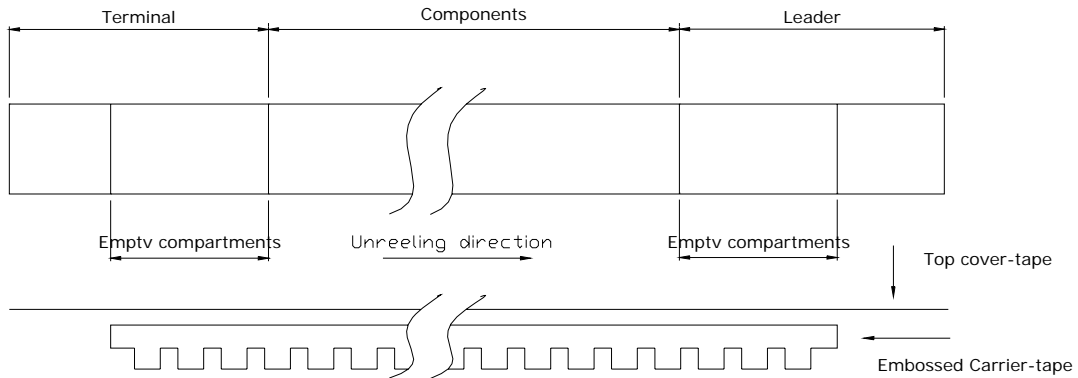

h.) Joint of tape

The carrier-tape and top cover-tape should not be jointed.

i.) Release strength of cover tape

It has to between 0.1N to 0.7N under following condition.

Pulling direction 165° to 180°

Speed 300mm/min.

Otherwise unless specified.

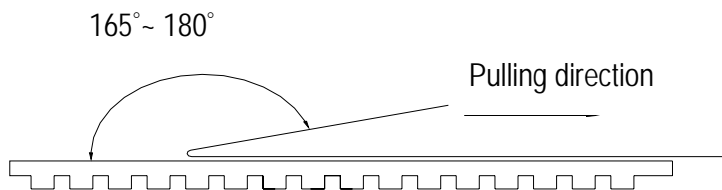

Other standards shall be based on JIS C 0806-1990.

Title HSX321S QUARTZ CRYSTAL SPECIFICATION				Country of origin <b>TAIWAN FACTORY</b> <b>THAILAND FACTORY</b>		
Date	Confirm	Check	Prepare	Spec. No.	Rev.	Page
2009/10/23	F. S. TSAI	C. L. WANG	U. F. CHEN	<b>X3S026000B71HZ-HPR</b>	1	8



## 5. Mechanical Performance

Item		Test Methods	Specifications Code
1	Natural Drop	Drop 3 times from the height of 50cm onto min. 30mm thickness hard wooden board.	A
2	Vibration	Frequency 10-55Hz, Sine Wave full amplitude of 0.8mm to X, Y and Z 3 axes, Duration of 2 hours to each axis.	A
3	Sealing Tightness	Leak Rate $1.0 \times 10^{-8}$ Pa-m <sup>3</sup> /sec. Max. Measured by Helium leak detector. – Fine Leakage.	---
4	Solderability	After applying ROSIN Flux, dipping in solder bath at 245deg.C +/- 5deg.C for 3 +/- 0.5 sec.	B

## 6. Environment Performance

Item		Test Methods	Specifications Code
1	Humidity	Temperature 60°C +/- 2°C, RH 90~95%, Duration of 240 hours. Back to room temperature first, then in 1~2 hours, the component shall be checked.	A
2	Storage in Low Temperature	-40deg.C +/- 2deg.C, Duration of 240 hours. Back to the room temperature first, then in 1~2 hours, the component shall be checked.	A
3	Storage in High Temperature	+85deg.C +/- 2deg.C, Duration of 240 hours. Back to the room temperature first, then in 1~2 hours, the component shall be checked.	A
4	Temperature cycles	-40deg.C +/- 2deg.C (30min) ↔ +85deg.C +/- 2deg.C (30min) 25 cycles. Back to the room temperature first, then in 1~2 hours, the component shall be checked.	A
5	VPS	FC-70(the boiling point: +215°C) Vapor for 30 sec. Back to the room temperature first, then in 1~2 hours, the component shall be checked.	A

Specifications code	Specifications
A	Frequency variation shall be within +/- 5ppm and equivalent resistance shall be within the specification after the test
B	More than 90% of lead shall be covered by new solder.

Title HSX321S QUARTZ CRYSTAL SPECIFICATION				Country of origin <b>TAIWAN FACTORY</b> <b>THAILAND FACTORY</b>		
Date	Confirm	Check	Prepare	Spec. No.	Rev.	Page
2009/10/23	F. S. TSAI	C. L. WANG	U. F. CHEN	<b>X3S026000B71HZ-HPR</b>	1	9

## 7. Supplement

### 7.1.Soldering

7.2.Please stay with our proposed reflow condition and do then soldering 2 times max.

**Available for Lead Free Soldering**

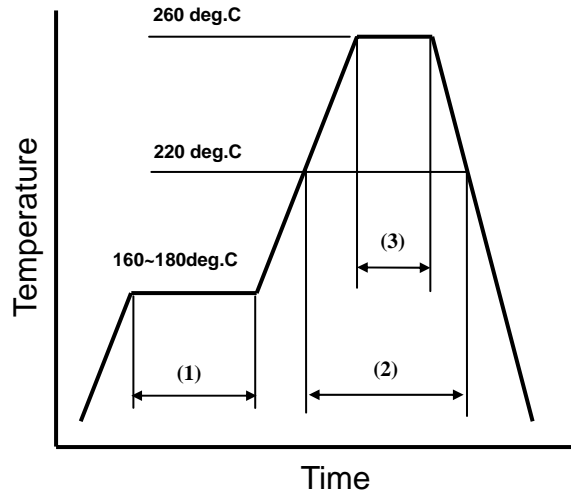

(1)	Preheat	160~180 deg.C	120sec.
(2)	Primary heat	220 deg.C	60sec.
(3)	Peak	260 deg.C	10sec. Max.

### 7.3.Land pattern layout(Example)

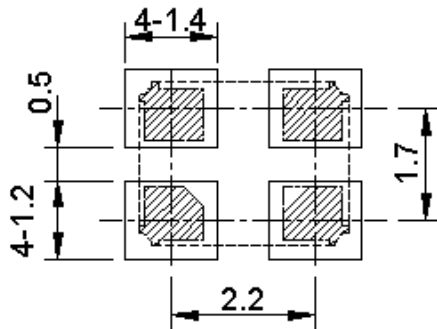

### 7.4.Solder iron (Example)

Bit temp.:350°C max.,Time:3sec max. ,Each terminal solder a 1 time max.

Title HSX321S QUARTZ CRYSTAL SPECIFICATION				Country of origin <b>TAIWAN FACTORY</b> <b>THAILAND FACTORY</b>		
Date	Confirm	Check	Prepare	Spec. No.	Rev.	Page
2009/10/23	F. S. TSAI	C. L. WANG	U. F. CHEN	X3S026000B71HZ-HPR	1	10

**HARMONY ELECTRONICS CORP.**

### 7.5.Mounting

This component is designed for automatic insertion.

However, you are requested to do the trial with your insertion machine in order to be sure of proper operation and no damage of component.

Please pay attention to board warp which may damage the component and cause Soldering Process.

### 7.6.Cleaning

Cleaning liquid which corrodes Nickel shall not be used

It may cause the problem on the surface, color, marking etc.

Ultra-sonic cleaning is possible, however, you are requested to check on your board.

Because we only checked as single unit.

### 7.7.Storage

Please keep away from high temperature and high humidity ,which may cause put solderbility. No direct Sunlight, No dew as well.

Title <b>HSX321S</b> <b>QUARTZ CRYSTAL SPECIFICATION</b>				Country of origin <b>TAIWAN FACTORY</b> <b>THAILAND FACTORY</b>		
Date	Confirm	Check	Prepare	Spec. No.	Rev.	Page
<b>2009/10/23</b>	F. S. TSAI	C. L. WANG	U. F. CHEN	<b>X3S026000B71HZ-HPR</b>	1	11

**HARMONY ELECTRONICS CORP.**

### 8. Flow Chard

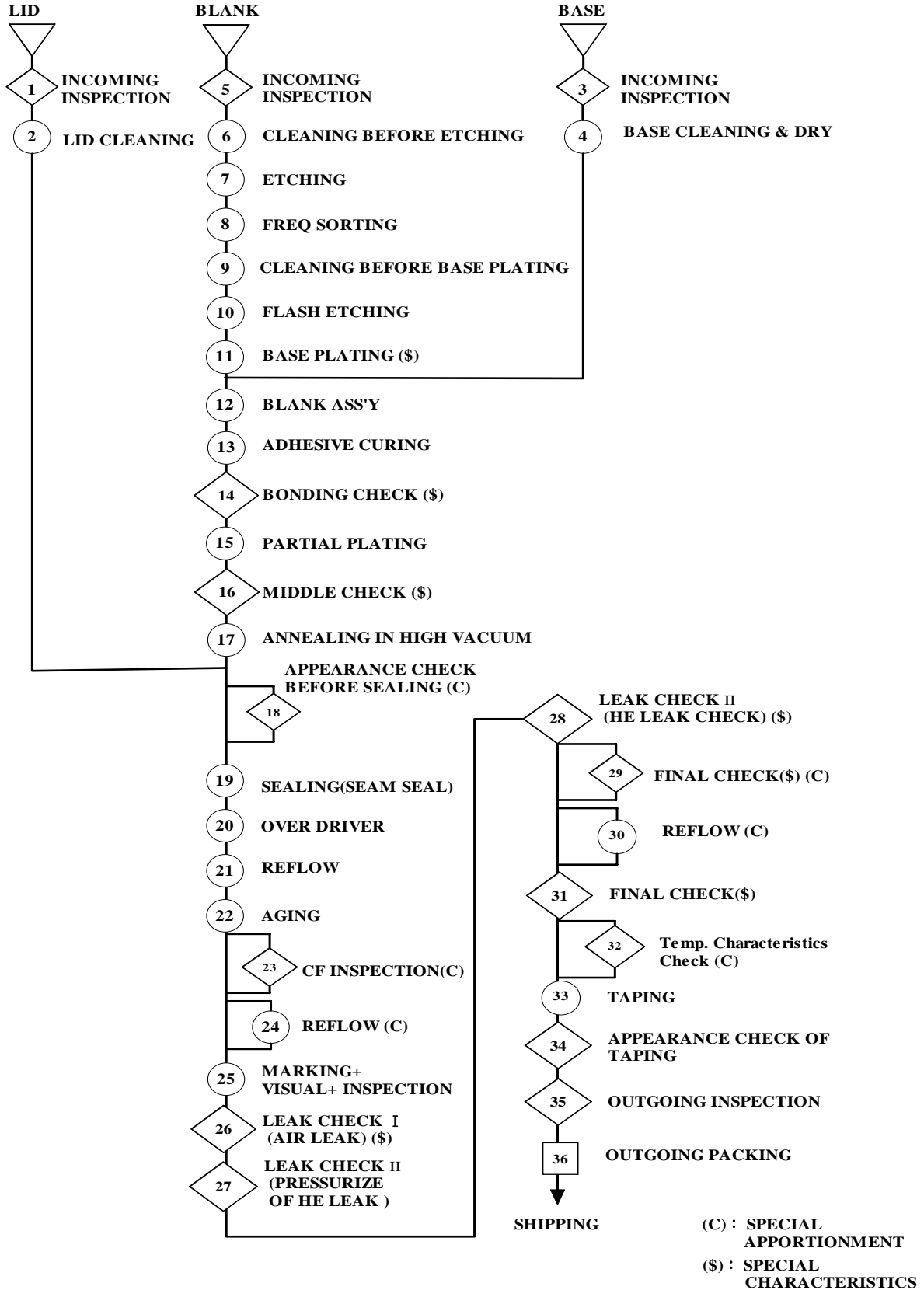

Title HSX321S QUARTZ CRYSTAL SPECIFICATION				Country of origin <b>TAIWAN FACTORY</b> <b>THAILAND FACTORY</b>		
Date	Confirm	Check	Prepare	Spec. No.	Rev.	Page
2009/10/23	F. S. TSAI	C. L. WANG	U. F. CHEN	X3S026000B71HZ-HPR	1	12

9. Environmental Workload Chemical Substance Components List

Environmental Workload Chemical Substance Components List		
Chemical Substance Components	TYPE	H(D)SX321S
	PERCENTAGE	19(mg) ppm
Si		0.0437 8.303
Au		0.1463 27.797
Co & Co Compound		1.1286 214.434
Mo & Mo Compound		0.0380 7.220
Ag		0.3952 75.088
Cu		0.1102 20.938
Cr & Cr Compound		0.0380 7.220
Al		4.7234 897.446
Mn & Mn Compound		0.0228 4.332
W & W Compound		0.1843 35.017
Ni & Ni Compound		2.8424 540.056
Fe		3.8437 730.303

Title HSX321S QUARTZ CRYSTAL SPECIFICATION				Country of origin <b>TAIWAN FACTORY</b> <b>THAILAND FACTORY</b>		
Date	Confirm	Check	Prepare	Spec. No.	Rev.	Page
2009/10/23	F. S. TSAI	C. L. WANG	U. F. CHEN	X3S026000B71HZ-HPR	1	13



EXCEL EXPORT PRINTOUT FORMAT

Run Name:

Run Date : 23-10-2009 1:11 pm

S&A 250B: 9.40 Report: 4.60

Description:

Reference Fr: 26000000 (Using Measured FL)

Power: 100.00 uW Into 20.0 ohms

PL: No Load CL: 7.20 pF

Crystal	First Failure	FR Hz	FL Hz	FL ppm	RR Ohms	C0 pF	C1 fF	C0/C1	L mH	Q k	TS ppm/pF	DLDH2 Ohms	FDDLH ppm	RLD2 Ohms	DLD2 Ohms	FDDL ppm
High Limit					30.0	2.00								30		
Low Limit																
1	PASS	25992879	26000025	0.96	11.37	1.29	4.65	277.52	8.07	115.85	32.24	0.09	0.02	11.49	0.19	0.90
2	PASS	25992937	26000030	1.14	11.02	1.27	4.60	276.27	8.15	120.85	32.05	0.15	0.03	11.11	0.20	0.87
3	PASS	25992800	26000028	1.08	13.77	1.29	4.70	274.98	7.97	94.55	32.60	0.10	0.03	13.76	0.32	0.83
4	PASS	25992882	26000021	0.82	11.15	1.27	4.63	273.77	8.10	118.65	32.28	0.10	0.02	11.20	0.18	0.98
5	PASS	25992861	26000036	1.37	12.24	1.32	4.68	281.62	8.01	106.87	32.25	0.15	0.02	12.37	0.18	0.89
6	PASS	25992583	25999756	-9.40	13.67	1.27	4.66	273.63	8.05	96.22	32.42	0.13	0.01	13.99	0.36	0.60
7	PASS	25993159	26000264	10.16	9.64	1.29	4.62	278.64	8.11	137.51	32.07	0.15	0.03	9.71	0.20	0.94
8	PASS	25993076	26000278	10.68	12.29	1.28	4.68	274.46	8.01	106.43	32.51	0.07	0.02	12.42	0.16	0.79
9	PASS	25993053	26000266	10.25	10.48	1.29	4.69	274.33	8.00	124.66	32.55	0.15	0.02	10.58	0.17	0.88

MAX	25993159	26000278	10.68	13.77	1.32	4.70	281.62	8.15	137.51	32.60	0.15	0.03	13.99	0.36	0.98
MIN	25992583	25999756	-9.40	9.64	1.27	4.60	273.63	7.97	94.55	32.05	0.07	0.01	9.71	0.16	0.60
X-bar	25992914	26000078	3.01	11.74	1.29	4.66	276.13	8.05	113.51	32.33	0.12	0.02	11.85	0.22	0.85
3S	513	505	19.42	4.16	0.05	0.10	8.04	0.18	41.61	0.60	0.09	0.02	4.26	0.22	0.33

