



# Conductive Polymer Aluminum Solid Capacitors PRODUCT SPECIFICATION

Date :

Product Description : Conductive Polymer Aluminum Solid Capacitors (Multi-layer Type)

MPL33730DG19TRX2

SUPPLIER	
PREPARED (拟定)	CHECKED (审核)
赵安平	刘渭清

CUSTOMER	
APPROVAL (批准)	SIGNATURE (签名)

**Contents**

< No. & Items >	< page >
1. Scope·····	3
2. Part Number Description·····	3
3. Descriptions·····	3
3-1    Dimensions	
3-2    Rated Voltage	
3-3    Capacitance	
3-4    Capacitance Tolerance	
3-5    Packing	
4. Part Number and Minimum Packaging Quantity·····	5
4-1    Part Numbers and Standards	
4-2    Minimum Packaging Quantity	
5. Markings·····	7
6. Characteristics·····	7
7. Packaging·····	9
7-1    Carrier Tape Configuration and Dimension	
7-2    Tape Packaging	
7-3    Taping Leader	
7-4    Reel Configuration and Dimension	
8. Caution for Use·····	10
8-1    Limitation of the use	
8-2    Storage Condition	
8-3    Cautions for Use	
9. Proposal·····	13

1. Scope

These specifications are applied to Polymer Aluminum Electrolytic Capacitor for electronic equipment use.

Please contact us beforehand when you use it besides this use.

2. Part Number Description



- ①Series : MPL
- ②Capacitance : See 3.3
- ③Capacitance Tolerance : See 3.4
- ④Rated Voltage : See 3.2
- ⑤Dimensions : See 3.1
- ⑥Packing : See 3.5
- ⑦ESR Value : See 4.1
- ⑧Individual Specification Code : See 6.10

3. Descriptions

3.1 Dimensions

(mm)

Case Code	L	W	T	W1	S
G19	7.3±0.3	4.3±0.2	1.9±0.2	2.4±0.1	1.3±0.3

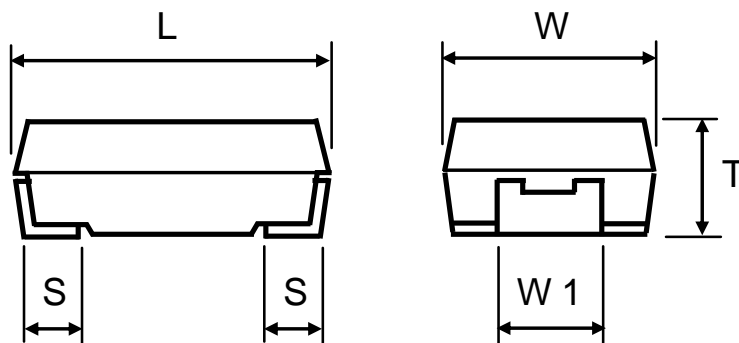

## 3.2 Rated Voltage

Code	0D
Voltage	2

## 3.3 Capacitance

These code are shown by three figures, the 1st and the second figure show the significant digit of the nominal capacitance, and the third figure shows the number of "0" following the significant digit.

Code	Capacitance
337	330 $\mu$ F

## 3.4 Capacitance Tolerance

Code	Tolerance
3	-35%~+10%

## 3.5 Packing

Code	Specification
TR	Tape & Reel

## 3.6 X— ESR level indicator

2 --- production line or special performance

## 4. Part Number and Minimum Packaging Quantity

## 4.1 Part Numbers and Standards

Part Number	Rated Voltage (V.DC)	Cap. ( $\mu$ F)	Cap Tol. (%)	Case Size	ESR (m $\Omega$ ) 100KHz/ +20 $^{\circ}$ C	Leakage Current ( $\mu$ A)	Ripple Current (Arms) 100KHz At105 $^{\circ}$ C
MPL33730DG19TRX2	2	330	-35%~+10%	G19	9	66	3.0

The temperature coefficient of the max ripple current:

	$T \leq 45^{\circ}\text{C}$	$45^{\circ}\text{C} < T \leq 85^{\circ}\text{C}$	$85^{\circ}\text{C} < T \leq 105^{\circ}\text{C}$
2V~6.3V	2	1.5	1.0
10V~35V	1.5	1.3	1.0

4-2 Minimum Packaging Quantity

Case Size	Minimum Packaging Quantity(pcs)
G19	3,500

5. Markings

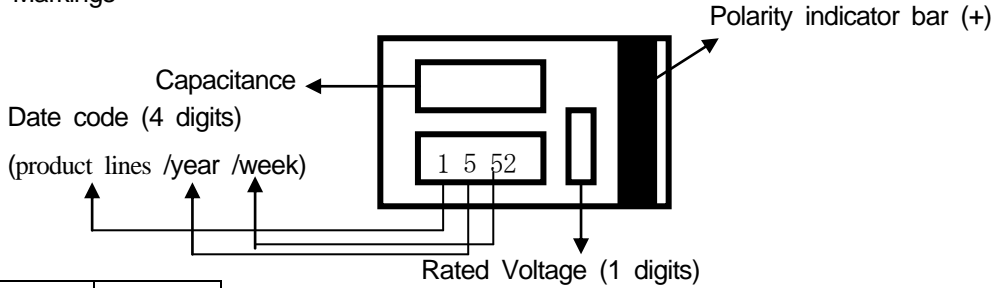

year	code
2011	1
2012	2
2013	3
2014	4
2015	5
2016	6
2017	7
2018	8
2019	9

Week	1	2	3
Code	01	02	03

.....

Week	24	25	26
Code	24	25	26

.....

Week	27	28	29
Code	27	28	29

.....

Week	50	51	52
Code	50	51	52

Rated Voltage Code (1 digits)

Code	Voltage
d	2
e	2.5
g	4
j	6.3
k	8
A	10
B	12.5
C	16

6. Characteristics

No	Item	Characteristics	Test Conditions
1	Operating temperature range	-55°C~+105°C	
2	Leakage Current	$\leq 0.1CV$ for W.V.:2V~8V $\leq 0.3CV$ for W.V.: $\geq 10V$	Series resistor: 1000 ohm Applied voltage: Rated Voltage Measuring after 2 minutes of application Please conduct pre-conditioning below, if you have a doubt. Pre-conditioning: • Temperature: room temp. • Applied voltage :Rated Voltage • Series resistor:1000 ohm • Charge time:30 min.
3	Capacitance tolerance	(See No.4.1)	Measuring frequency: 120Hz $\pm 10\%$ Measuring circuit: Equivalent series circuit Measuring voltage: +1Vr.m.s. Measuring temperature: 20 °C
4	Dissipation Factor	$\leq 0.06$	
5	ESR	(See No.4.1)	
6	Allowable Ripple Current	(See No.4.1)	Measuring frequency: 100kHz $\pm 10\%$ Part temperature: +20 to +105 °C

Specification No	7/13
------------------	------

No.	Item		Characteristics	Test Conditions
7	Solderability		More than 95% of each terminal face is covered by new solder	Eutectic solder: H60A Flux: Ethanol solution of 25% rosin Solder temperature: 235 ±5 °C Immersing time: 5 ±0.5s
8	Moisture resistance under no bias	Leakage Current	200% of initial specified value	Test temperature: 60±2°C Relative humidity: 90~95%RH Test time: 500+24, -0h
		Capacitance Change	-20% and +70% of initial measured value	
		Dissipation Factor	200% of initial specified value	
		Appearance	No defects or abnormalities	
9	Shelf life	Leakage Current	(See No.6.2)	Test temperature: 105±5°C Test time: 1000+24, -0h
		Capacitance Change	±20% of initial measured value	
		Dissipation Factor	200% of initial specified value	
		Appearance	No defects or abnormalities	
10	Endurance	Leakage Current	200% of initial value	Test temperature: 105±5°C Test time: 1000+48, -0h Applied voltage: Rated Voltage
		Capacitance Change	±20% of initial measured value	
		Dissipation Factor	200% of initial specified value	
		Appearance	No defects or abnormalities	
11	Surge	Leakage Current	(See No.6.2)	Temperature: +85°C for W.V. 2V~10V Rated voltage x1.25 for W.V. 2V~10V Current Limiting resistance: 33 ohm(in series) for W.V. 2V~10V: 33 ohm(in series) for W.V. 2V~10V 30 sec. each, 1000 times
		Capacitance Change	±10% of initial measured value	
		Dissipation Factor	≤0.06	
		Appearance	No defects or abnormalities	

The measurement condition in No.2 to 4 applies to No.8 to 12.

7. Packaging

7.1 Carrier Tape Configuration and Dimension

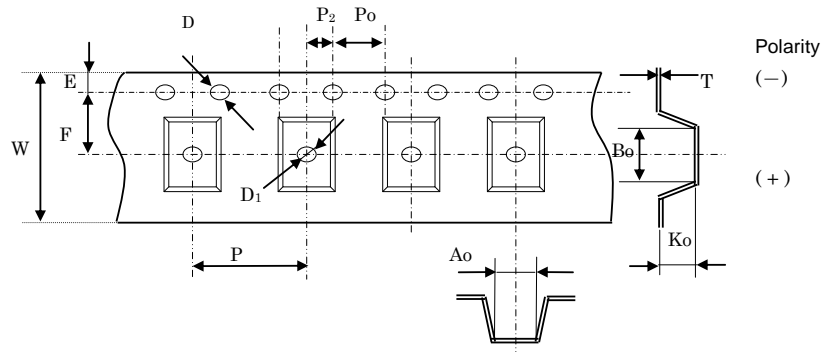

Case Code "G19"

(mm)

	$W+0.3-0.2$	$P\pm 0.20$	$A0\pm 0.20$	$B0\pm 0.20$	$K0\pm 0.20$	Cumulative Pitch
Dimension	12.00	8.00	4.60	7.60	2.16	40.00±0.40

	$D+0.20 -0$	$E\pm 0.20$	$P0\pm 0.20$	$T\pm 0.10$	$P2\pm 0.10$
Dimension	1.50	1.75	4.00	0.229	2.00

7.2 Tape Packaging

Capacitors will be inserted in embossed carrier tape that will be sealed with cover tape as described below.

No more than half of a sprocket hole will be covered by cover tape.

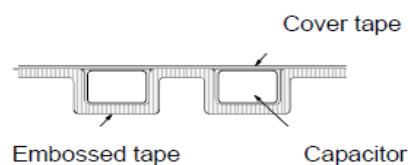



7.3 Taping Leader

Tape has a leader and a trailer as described below.

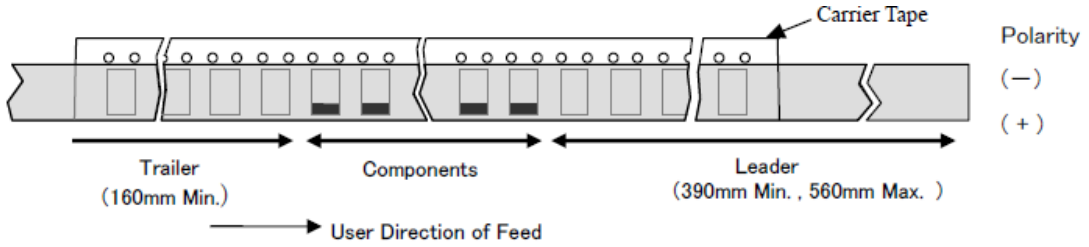

7.4 Reel Configuration and Dimension

Tape with capacitors is wound in a reel as described below.

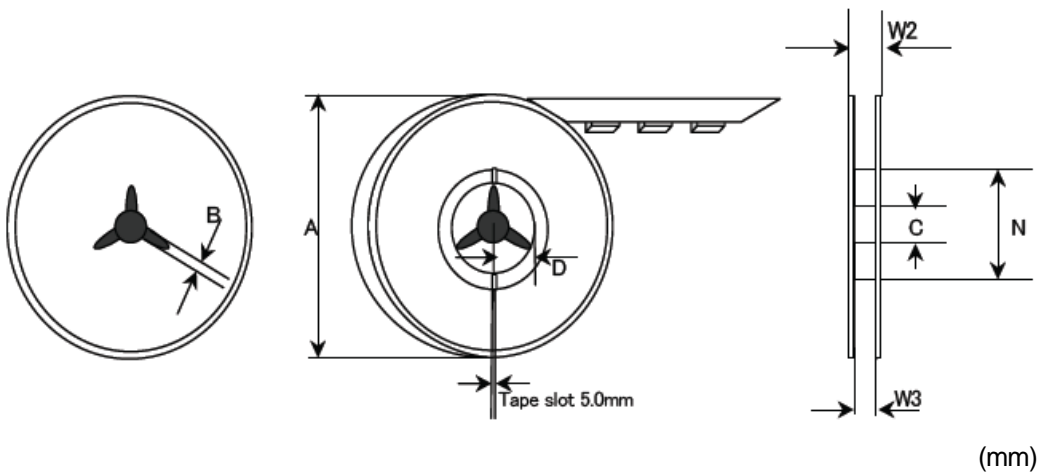

(mm)

Reel size	Tape width	A	B	C	D	N	W2	W3
Φ330	12	330.0MAX	2.0±0.18	13.0±0.2	11.9±0.1	100.0±1.0	17.5±1.0	13.5±1.5

## 8. Caution for Use

## Caution



## 8.1 Limitation of the use

Please contact us before using our products for the applications listed below which require especially high reliability for the prevention of defects which might directly cause damage to the third party's life, body or property.

①Aircraft equipment ②Aerospace equipment ③Undersea equipment  
④Power plant control equipment ⑤Medical equipment ⑥Transportation equipment  
(vehicles, trains, ships, etc.) ⑦Traffic signal equipment ⑧Disaster prevention /  
crime prevention equipment ⑨Data-processing equipment ⑩Application of similar  
complexity and / or reliability requirements to the applications listed in the above.



## Caution

## 8.2 Storage Condition

<1>Term of warranty for this product is two years after packaging in a moisture-proof bag, under the conditions below with sealed packaging.

Recommended storage environment: Room temperature: 5-30 degree

Humidity: no more than 60%RH

<2>Polymer aluminum electrolytic capacitors should be stored in a dry atmosphere, avoiding direct sunlight and condensation. If capacitors are kept at a higher humidity, the following problems may occur:

- ①Leakage current will increase at the beginning of use and damage the circuit.
- ②Moisture absorbed in a resin will evaporate and expand with heat of mounting and damage the mold resin.

<3>Please confirm a dry state with a humidity indicator card after open immediately.

If 20% indication was in a pink state after opened, it is recommended to bake under the conditions below as countermeasures against the problems ① and ② in <2> above respectively.

<4> The capacitors should be kept dry using desiccators or any other methods after unsealing the moisture-proof packaging. If more than two weeks has passed under the recommended storage environment specified above after unsealing the packaging, it is recommended to apply voltage and to bake under the conditions below, as countermeasures against the problems ① and ② in <2> above respectively.

① Recommended voltage conditions:

Applied voltage: rated voltage

Time: 30 minutes

Temperature: room temperature

Current limiting resistance: 1000Ω(series connection)

② Recommended baking conditions:

Temperature: 60(+0, -5) degree C

Time: 168 hours

<5> This product meets MSL-3.

**⚠ Caution**

**8.3 Cautions for Use**

**<1> Polarity**

Polymer aluminum electrolytic capacitor is polarized. Please not to reverse the polarity when using. If reverse voltage is applied, it may damage the oxide film and the capacitor itself. Please verify the orientation of the capacitor before use in accordance with the drawing of "Markings" in Item 5.

**<2> Allowable Ripple Current**

Please not to apply ripple current exceeding the allowable value specified in the standards in Item 4.1. If excessive current is applied, it may generate heat and the heat may damage the capacitor. The sum of DC voltage and the peak AC voltage shall not exceed the rated voltage. The sum of the DC voltage and the peak AC voltage shall not allow a voltage reversal.

**<3> Reflow Soldering**

- ① Please not to apply excessive force to the capacitor during insertion as well as after soldering. The excessive force may result in damage to electrode terminals and/or degradation of electrical performance.
- ② Resistance testing to reflow soldering was conducted in accordance with the reflow profile described in Figure 1. If this profile is adopted, reflow soldering can be repeated no more than two times.

**■ Recommendable reflow soldering temperature 260°C**

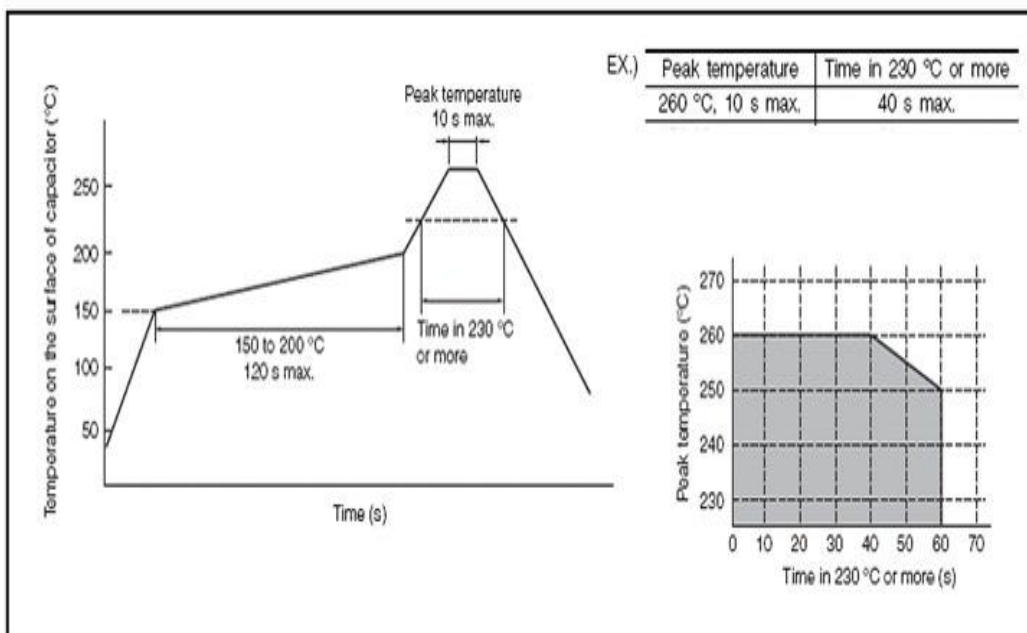

③Please refer to figure below for designing land pattern.

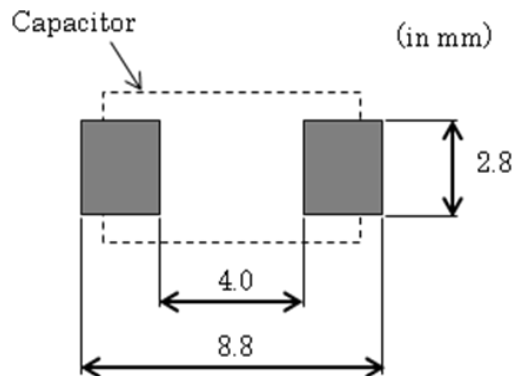

#### <4>Disposal

Polymer aluminum electrolytic capacitors should be disposed of as industrial waste in accordance with laws.



#### 10. Proposal

- ①When you use, please evaluate in a state mounted by your product.
- ②Please do not use this product other than the mention contents of this specifications.
- ③We think that it is not appropriate to mention a contract matter about the business in specifications, a drawing, other technical documentations.

Therefore, we invalidate it when there is a mention about the range of the responsibility of us such as a guarantee of quality, PL, industrial property, the export control in these technical documentations that your company was made.

Please offer these matters separately in the basic contract document etc...